

DGE MOTORSPORTS

PRIDE IN QUALITY AND SERVICE

Installation Guide

1990—2005 Mazda Miata Tall Person Roll Cage

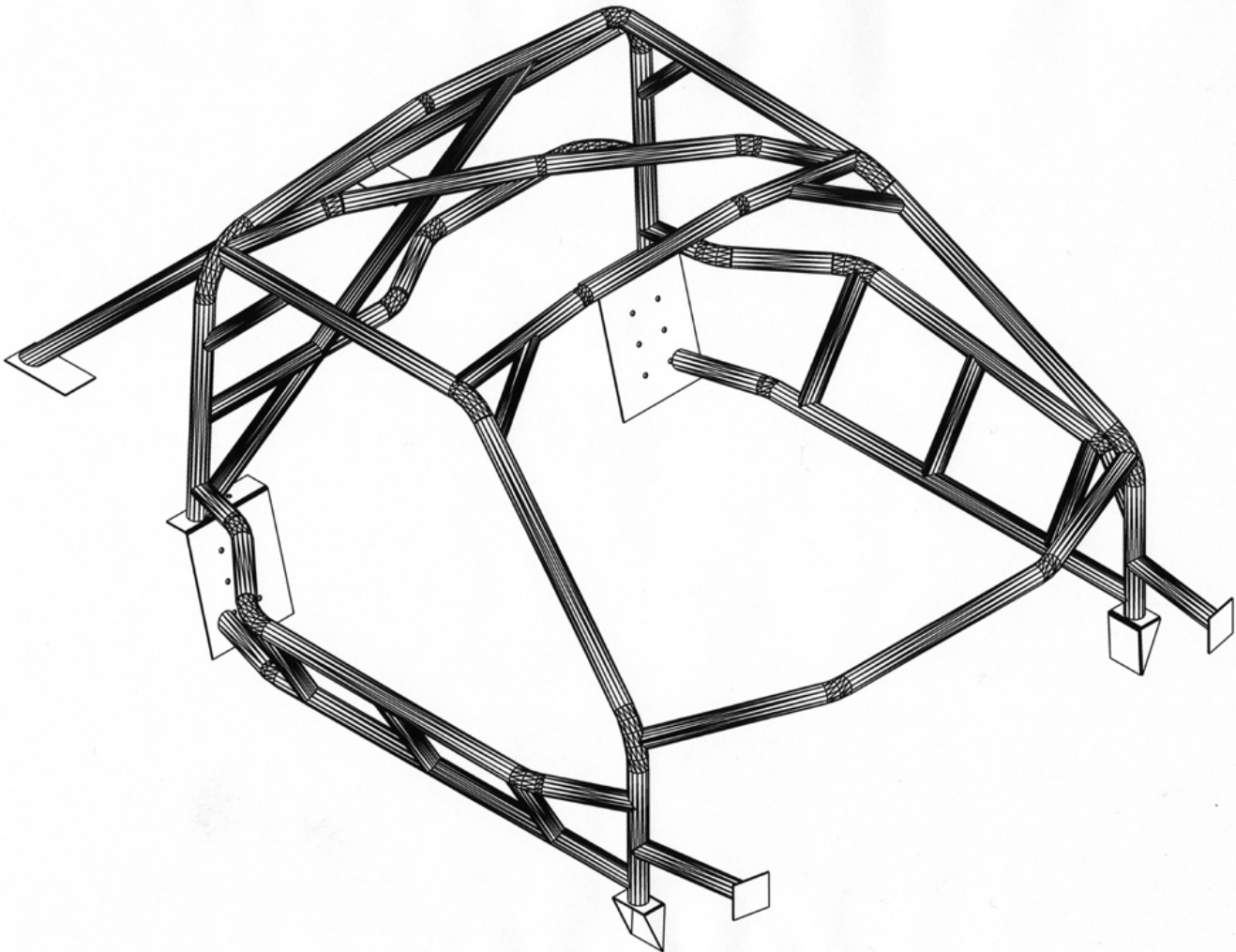

Thank you for purchasing a DGE Motorsports Roll Cage kit.

Table of Contents

Disclaimer_____	3
Copyright_____	3
Part #'s and descriptions_____	4
3D top view with part #'s_____	5
3D driver side view with part #'s_____	6
3D passenger view_____	7
3D front view with part #'s_____	8
Car prep for cage installation_____	9
Prep for perch installation_____	9
Perch installation_____	10
Main hoop installation_____	11
Rear down tube prep_____	12
Rear down tube installation_____	12
Seat brace bar installation_____	13
Hoop diagonal installation_____	14
Forward down tube prep_____	15
Forward down tube installation_____	16
Dash bar prep_____	16
Dash bar installation_____	16
Eyebrow/Windshield bar installation_____	17
Firewall plate installation_____	17
Firewall tube installation_____	17
Door bar prep_____	18
Lower door bar installation_____	18
Upper door bar prep_____	18
Upper door bar installation_____	19
Door bar vertical installation_____	19
Roof diagonal installation_____	20
Welding process_____	20
Gusset placement_____	21
Heater blower installation_____	21
Dash prep and install_____	22

Disclaimer

David Gilbert Enterprises LLC. manufactured or distributed the components for use on vehicles designed and built by persons not associated or controlled by David Gilbert Enterprises LLC. No specific use is recommended, intended or implied. Because David Gilbert Enterprises LLC. is not in control of the installation of this product and some environments may subject components to severe stress, and because components are affected by many forces beyond the control of David Gilbert Enterprises LLC., these products are sold without warranty, merchantability or of fitness for any specific purpose. No warranty expressed or implied accompanies these products and the purchaser and/or user having inspected the components makes his/her sole determination of their suitability for use in an application of his/her own design. By installation of these components the user or installer assumes all risk of damage, injury or even death.

This installation guide is meant to be used only as a reference during the installation process. Following this installation guide in no way guarantees your safety or the integrity of the roll cage once the cage is installed. The user assumes all responsibility for contracting with a certified welder/fabricator for the installation to meet the rules of the sanctioning body for which the end user intends to participate.

Please read the entire manual before starting installation. Reading the manual before you start the installation process will give you some insight of the process and should make the installation easier. There will be some pieces that will need to be fit but will need to be removed at a later time to achieve 100% welding.

Part #'s and Description

Description	# of Bends	Qty	Part #
Main Hoop Perch Plate	1	2	89
Front Perch	1	2	90
Front Perch Sides	0	4	91
Rear Down Tube Landing Plate	0	2	96
Main Hoop	3	1	150
Driver Side Door Frame Bar	2	1	101
Passenger Side Door Frame Bar	2	1	102
Upper Nascar Door Bar	3	2	103
Lower Door Bar	1	2	104
Door Bar Vertical	0	2	105
Door Bar Vertical	0	2	106
Door Bar Vertical	0	2	107
Roof Diagonal Bar	3	1	113
Eyebrow/Windshield Bar	2	1	114
Seat Brace Bar	3	1	115
Dash Bar	2	1	116
Hoop Diagonal	0	1	117
Rear Down Tubes	0	2	118
Firewall Tubes	0	2	121
Firewall Plates	0	2	122
Tube Gussets	0	4	123
Plate Gussets	0	16	
Heater Blower Tab	0	1	

Optional Part #'s and Description

Description	# of Bends	Qty	Part #
X-Brace	0	2	124

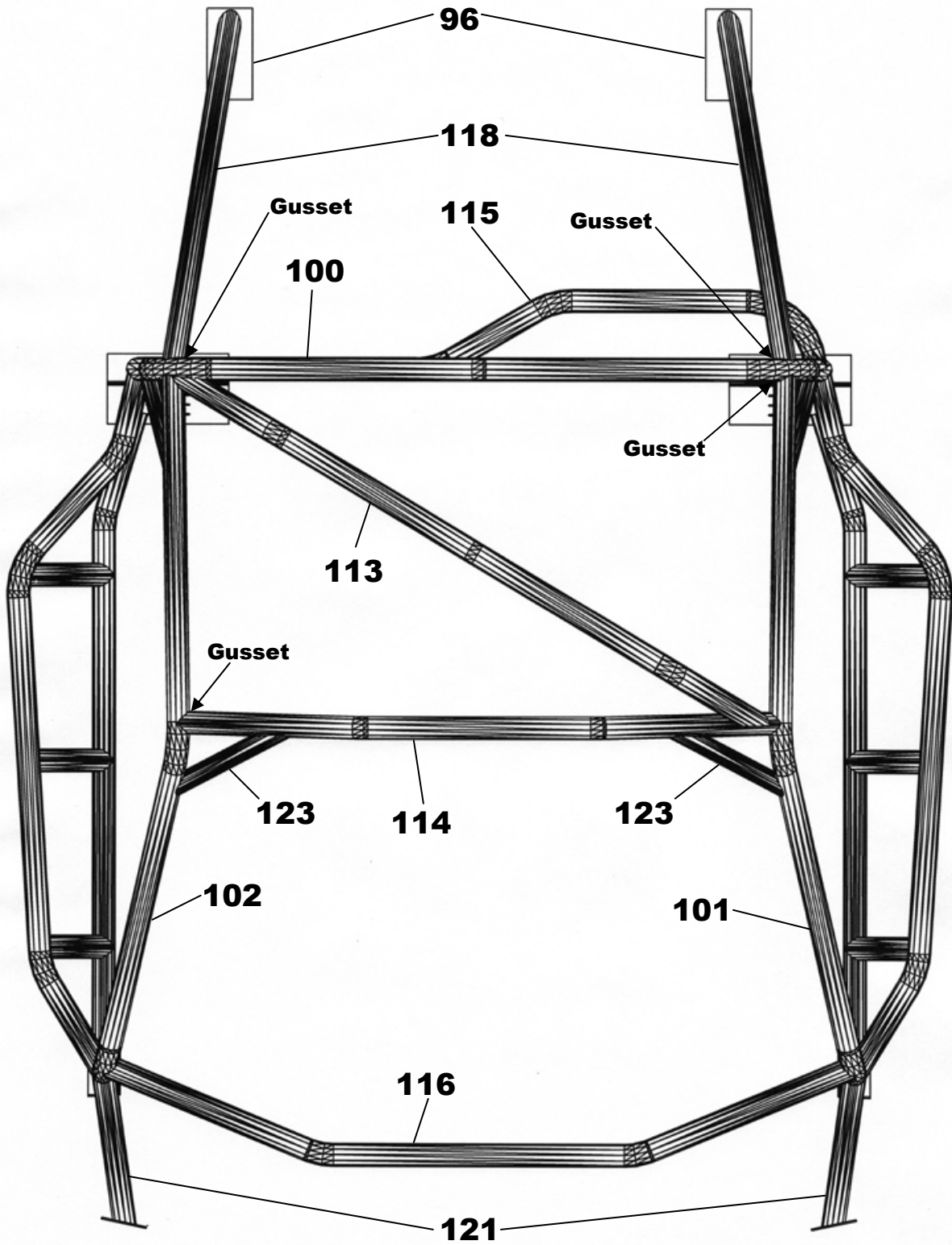

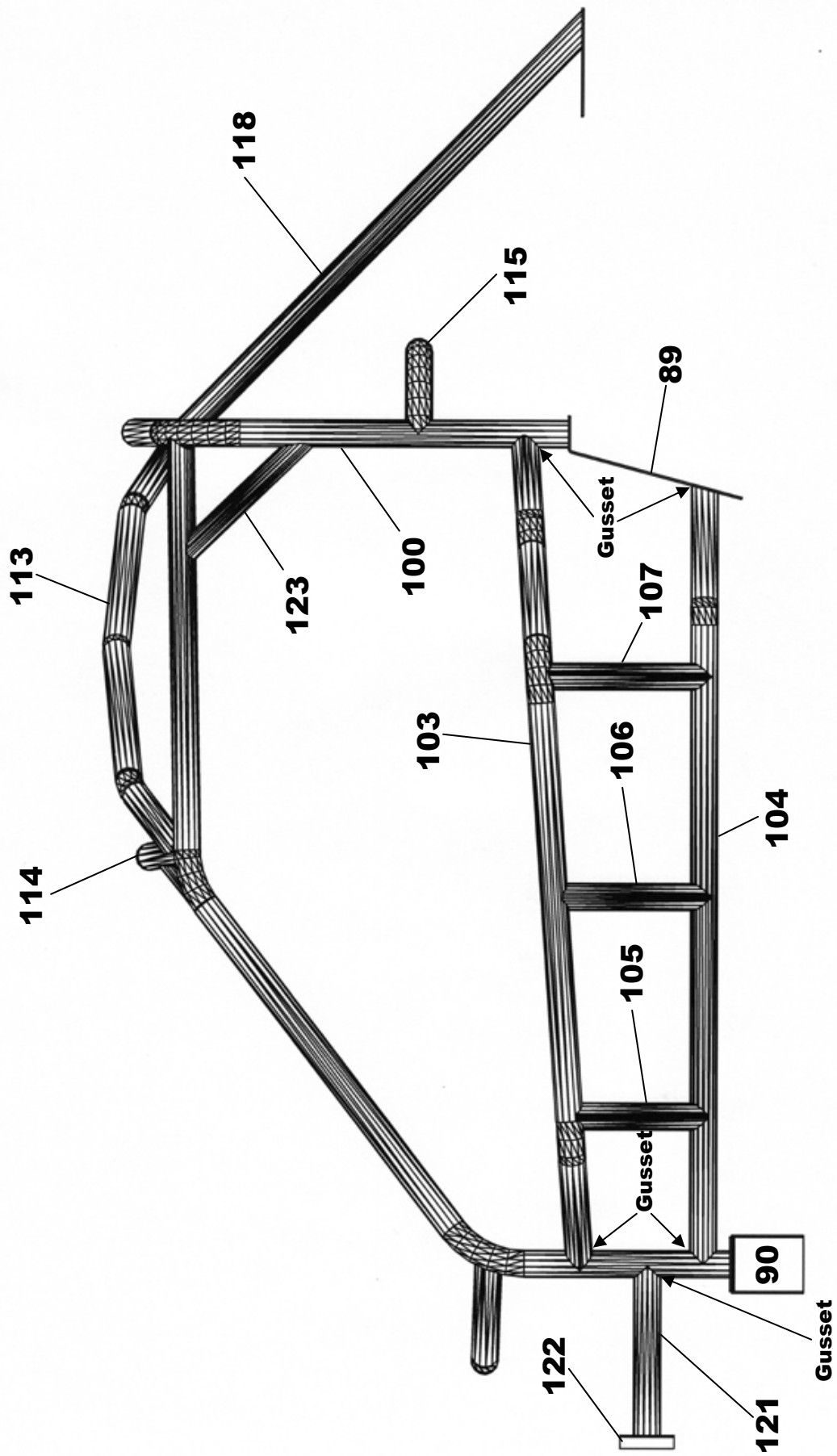

**All Part #'s for this
page are the same as
on page 6.**



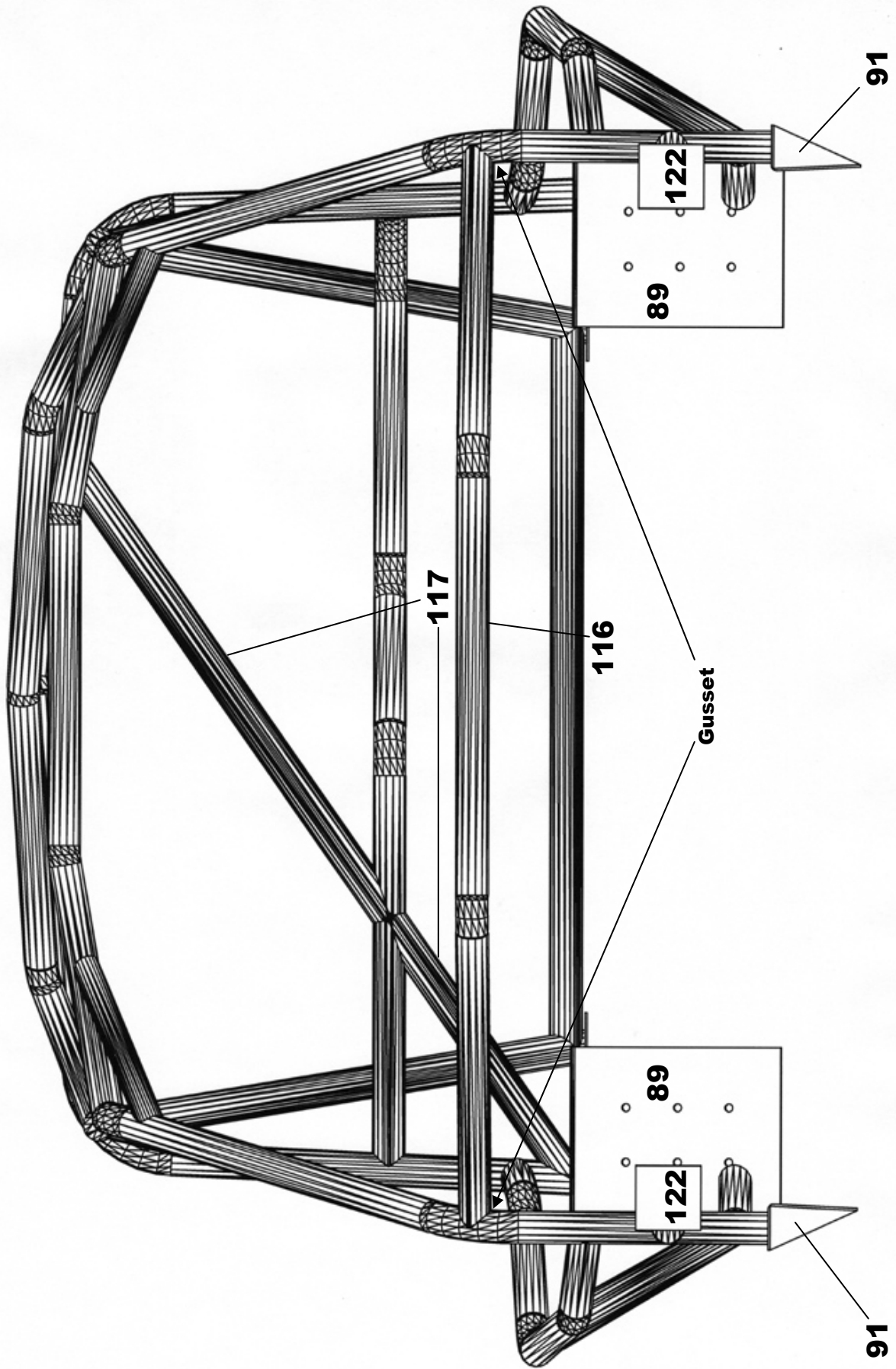

Car Prep For Cage Installation

Remove the following items from the car:

- Soft top and all associated mounting components
- Battery
- ECU (Remove this to prevent possible damage from welding)
- Dash
- Steering column
- All interior pieces (seats, door panels, carpet, visors, etc.)
- Fuel filler neck and hose
- Remove fuel tank for safety while welding (**NOTE: We usually soak a rag with water and stuff it in the filler neck and then cover the neck and vent with a wet towel. Please be careful when welding around the fuel tank openings.**)



Perch Preparation

Once the interior is stripped you need to prep the areas where the perches will be located for welding. See the following pics.

- Locate where all 8 perches will go and mark around the plates with a sharpie.
- Remove all paint and seam sealer in and around all marked areas.

NOTE: Take your time removing as much seam sealer as possible around the areas to be welded. This will make welding much easier. Dig as much out as possible with a pick from between the joints. We have found that using a torch to burn the rest out works well. Removing the undercoating from the bottom side of the car directly below the areas to be welded wherever possible also helps.

Pic 1 (Front Perch)

The white arrow in Pic 1 indicates where the front edge of the Front Perch should be located. The side of the front perch should just cover this hole. The black arrow shows where the top of the perch should sit. This allows you to get the door frame bars as close to the body as possible to maximize foot compartment room.

Pic 2 (Rear Down Tube Plate)

The arrows in Pic 2 indicate where the plates should be located. The plate should be about 1/16" off the sheet metal edge (white arrow) and up tight against the rear sub frame stud. (black arrow)

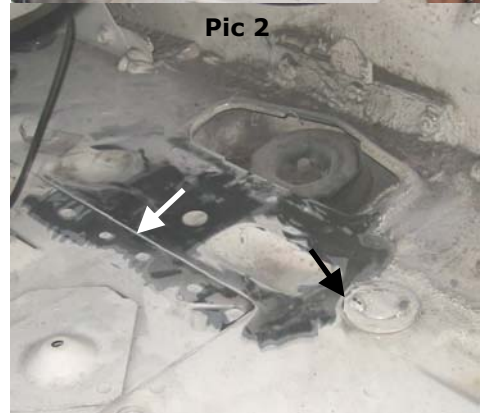
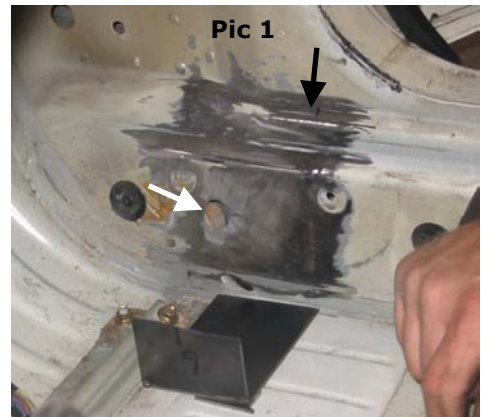

Perch Installation

Since no 2 cars are exactly the same, some grinding and minor adjustments will be required to make the perches fit correctly.

Part #'s 90 & 91 (Front Perches)

- Position the bent Front Perch pieces as indicated on the page 9 and place 1 small tack on the top and bottom to hold in place while you fit the side pieces.
- Using a piece of cardboard or stiff paper, make templates for the front and rear side pieces for the front perch.
- Once you are satisfied with the templates transfer them to the side pieces and cut.
- Grind pieces to achieve best possible fit.
- Tack the side pieces onto the bent piece only and remove the whole unit from the car and weld the sides to the bent piece.
- Once the sides are welded, reinstall in car and weld completely.



Part #89 (Main Hoop Perch)

- Grind the edge indicated by the arrow in pic 1 to fit.
- When satisfied with the fit, tack in place around the outer perimeter only.
- From the underneath side of the car you can use a hammer and work the sheet metal so there is not much of a gap between the plate and the body at the 4 bottom plug weld locations.
- Once you are happy with the fit, fill in the plug welds first and then weld the perimeter of the plates completely.



Part #122 (Firewall Plates)

The Firewall Plates should butt up to the 2 bolt bosses as indicated by the arrows and be centered vertically.

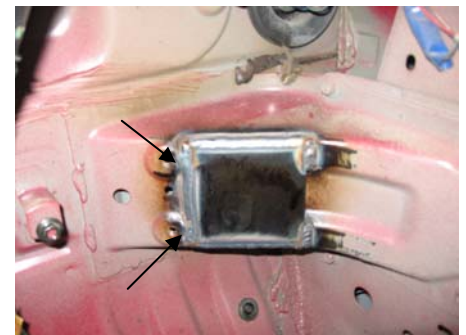

Part #96 (Rear Down Tube Plates)

- Position the Rear Down Tube Plates as indicated on page 9 and tack into place, again making sure to tack in several places to prevent the sheet metal from warping.
- Weld completely.



Fire Plate Installation

At this point you need to install the fire plates supplied with the kit. Once the main hoop is installed the fire plates are almost impossible to install.

Main Hoop Installation

NOTE: You must have your hardtop mounted to continue past this point. Set the hardtop in place and attach to the car to keep the top from moving around when fitting the hoop.

Part #100

1. Place the Main Hoop in the car and determine how much length needs to be removed from the bottom of the legs. **(For tightest possible fit remove no more than 1/4" at a time. Work up on fit slowly. Because the main hoop mounting plates are not flat, you will need to cut the bottom of the main hoop at a slight angle. Notching the hardtop for the corners of the hoop will give you an even tighter fit. Pic 1)**
2. Tack weld the hoop in place and make sure the hardtop fits on the car properly and does not hit the hoop.



Rear Down Tube Prep

- Locate where the holes will be drilled in the package tray for the rear down tubes to pass through. (Pic 1 and 2) The dimension in Pic 1 is 8 7/16" from the side. The dimension in Pic 2 is 3" (different from pic) from the rear. Measure from the points shown in the pics.
- Using a 1 3/4" hole saw, drill through the package tray.
- Deburr the holes.

NOTE: Some minor trimming of the holes may be required to get the tubes to land correctly on the hoop and rear down tube landing plates.



Rear Down Tube Installation

Part #'s 118

- Place rear down tube through hole in package tray and line up notch on main hoop. The main hoop end should line up where the forward down tubes will meet the main hoop as shown in the previous 3D renderings. **(NOTE: Some minor grinding may be required to the notch to get correct fitment.)**
- Cut tubes on approximately a 45 degree angle so they sit flat on the plates.
- Make any necessary adjustments to acquire good fit.
- Once satisfied with the fit, tack the tubes in place.

NOTE: The hardtop can be removed at this time to allow easier access for the following steps



NOTE: Before proceeding any further, you will need to have your seat mounted to locate the height of the Seat Brace Bar per the GCR or the rules of the sanctioning body for which you wish to participate.

Seat Brace Bar Installation

Part #115

- Layout the drivers side per Pic 1 at the bottom of the page. Put a straight edge along the front side of the bar per the dotted line and mark the driver side end. From that mark measure back 1 1/2" and place another mark. The circle indicates the notch you will take out. **(NOTE: The extra length on the driver side end is so you can clamp in the notcher. Depending on the height of your seat you may need to notch the stock shoulder belt tower. See pic 2)**
- With the seat in place, locate where the Seat Brace Bar will be installed on the main hoop and mark location.
- Using a hole saw, drill through the seat belt tower so the tube will pass through. Once the holes are close, cut the tower off through the middle of the holes you just made. **(Note: this will be tacked back in place once the seat brace bar and main hoop are installed)**
- Notch the driver side end so the bar is parallel to the ground.
- Position the Seat Brace Bar on your original layout mark on the driver side and mark the passenger side for notching making sure the bar is level.
- Notch passenger side.
- Once you are satisfied with the fit tack into place.

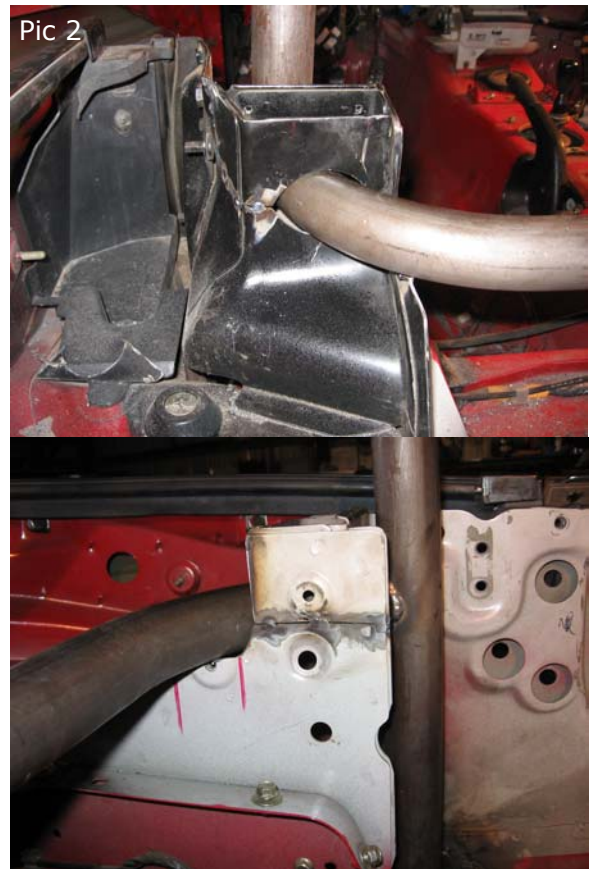

Pic 1

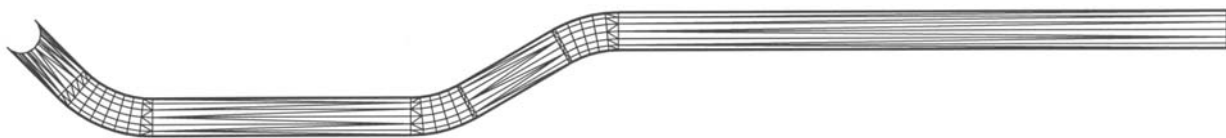

Hoop Diagonal Installation

Part # 117

(NOTE: The Hoop Diagonal comes as 1 piece but will need to be cut into 2 pieces in the following steps. Refer to the Picture below.)

- Position the Hoop Diagonal in the car and mark the approximate location where the tube will land on the driver side top, (#5) making sure it will not interfere with the seat or be too close to your helmet.
- Cut about a 45 degree angle on the passenger bottom where the diagonal meets the plate. #1
- Now make the notch on the passenger bottom where this tube will meet the Main Hoop. #2
- Mark the tube where it intersects the Seat Brace Bar and cut, leaving enough length for notching but not too much that you won't have enough tube for the other half of the diagonal.
- Notch the opposite end of the passenger side diagonal where it meets the Seat Brace Bar (#3).
- Once satisfied with the fit, tack into place at the Seat Brace Bar end only.
- Make the same angled notch for #4 as you did #3.
- Determine notch angle at #5 and make notch.
- Keep removing material till both pieces are in line with each other.
- Once satisfied with the fit, tack into place at both ends.

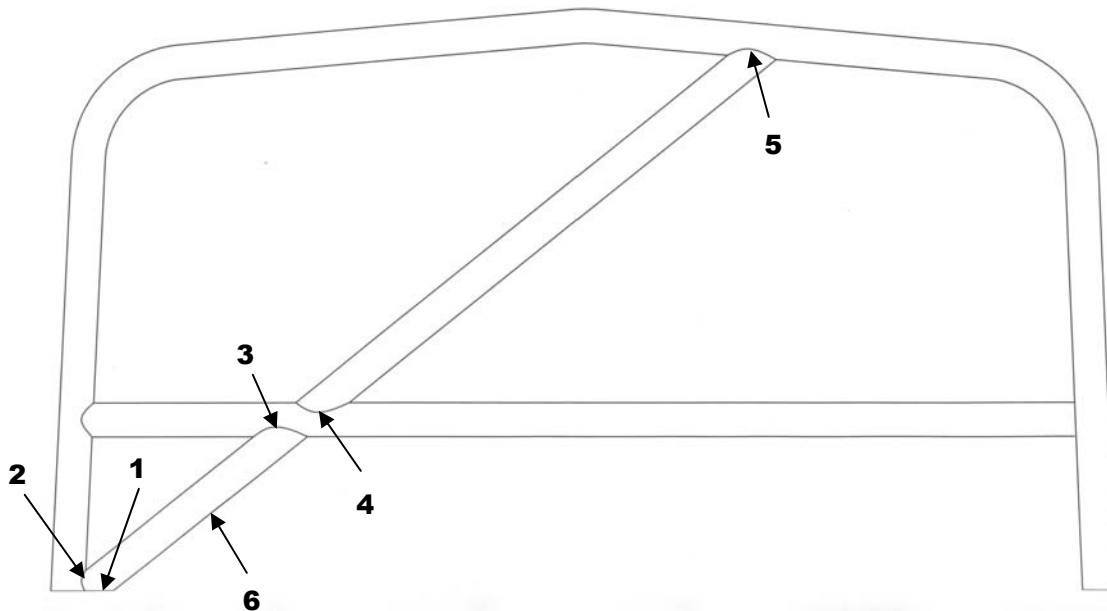

- Once the Hoop Diagonal is tacked in place, remove the Main Hoop assembly.
- Remove tube #6 so you can get a complete weld on the passenger end of the Main Hoop to the Hoop Plate
- Clean all broken tacks from perches and the Main Hoop.
- Weld the driver side of the Seat Brace Bar to the Main Hoop completely and the back side of the passenger side Seat Brace Bar.
- Reinstall Main Hoop and tack in place.
- Reinstall hardtop to make sure everything still fits.



- When your satisfied with the fit, weld the Main Hoop to the perches.
- Now position the lower Hoop Diagonal Piece (#6 from previous page) and tack in place.
- Now weld the Rear Down Tubes to the Main Hoop and their respective perches.

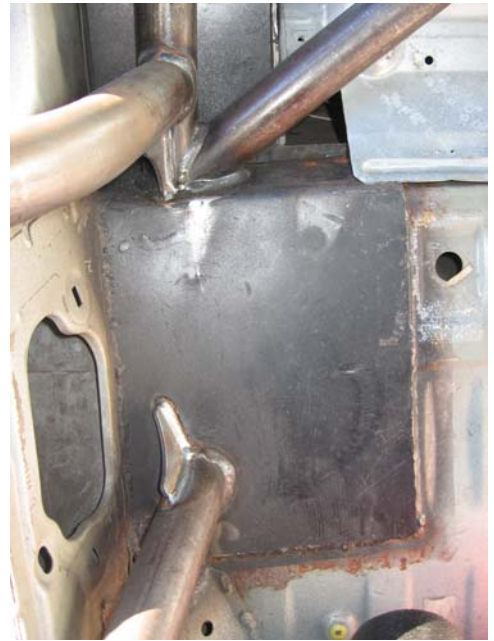

Forward Down Tube Prep

In preparation for the Forward Down Tube you need to remove part of the dash mounts on both sides of the car. Don't worry, you will still be able to bolt your dash in when we are finished.

- Drill out the spot welds that hold the back portion of the dash mount brackets (#1) and the heater mount tab(#2) as indicated in pic 1.
- Using a cut off wheel, cut along the edge indicated in pic 1, #3.
- Follow these same steps for the other side of the car.
- Pic 2 shows the pieces that are removed.
- Deburr all sharp edges and round any sharp corners.
- Using a small cut off wheel trim the A-Pillar plastic at the top of the windshield frame as shown in pic 3.

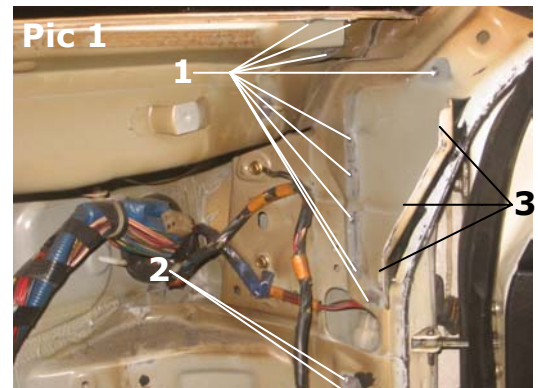

Door Frame Bar Installation

Part #'s 101 & 102

NOTE: The front lower leg of the Door Frame bars should not need any trimming. Even though it might look like they do, fit the back part to the Main Hoop before trimming anything from the front.

- Position Door Frame Bar in car and determine the placement of the notch at the Main Hoop.
- Notch the Main Hoop end until the front is sitting in the middle of the front perch.
- Once satisfied with the fit, tack into place
- Follow the same steps for the other side of car.



Dash Bar Installation

Part #124

NOTE: This piece is very challenging to install. Take your time and remove small amounts of material at a time so as not to make it too short. This piece should be left just a little bit long so it will push the Door Frame Bars out tight against the body of the car.

- Measure off each end of the Dash bar and place marks every 1/4". These are reference marks only so you can make sure and remove equal amounts of material from each end of the tube when notching.
- Remove 1 of the Door Frame bars and set the Dash bar in place.
- Determine notch angle and rotation.
- Notch 1 end only removing just enough material to create a complete notch and check for proper notch angle and rotation.
- Make any necessary adjustments to angle and rotation.
- Duplicate notch on other end of tube, removing an equal amount of material as you did the first notch.
- Try and reinstall the Door Frame bar you just removed with the Dash bar in place.
- If the Door Frame bar will not go in place, remove equal amounts of material from both ends of the Dash bar using the reference marks till you can get the Door Frame bar in place. **(NOTE: Again, remove small amounts at a time. The marks are for reference only. You do not need to notch to the next mark if the tube is too long. You can notch anywhere in between the marks as long as you remove equal amounts from both ends.)**



- Once you are happy with the fit, place small tacks on each end of the Dash bar and re-tack the Door Frame bar in place.

eyebrow/Windshield Bar Installation

Part # 114

NOTE: This piece will be left slightly long so it can be wedged into place to push the Door Frame Bars out as tight as possible to the A-Pillars.

- Measure off each end of the bar and place marks every 1/2". These are reference marks so you can make sure you remove equal amounts of material from each end of the tube.
- Set the Eyebrow bar on top of the 2 Door Frame Bars. **(NOTE: The eyebrow bar should lean slightly forward at the top.)**
- Mark location of notches on tube and notch both ends removing equal amounts from both ends starting at the first mark made earlier.
- Check notch angles and rotation and make any necessary adjustments.
- Continue notching equal amounts from both ends till you can wedge the bar in place.
- Once satisfied with fit, tack bar in place.



Firewall Tube Installation

Part # 121

- Place tube in car and determine cut angle and rotation of cut.
- Cut Firewall end, leaving slightly long.
- Check cut angle and rotation.
- Make any necessary adjustments.
- Cut till tube fits flat on plate.
- Tack in several places on Door Frame Bar end only. **DO NOT TACK TO PLATE.**



Door Bar Prep

- Remove windows, window regulators and inside door handles from doors.
- Remove sheet metal so the doors look something like Pic 1.



Lower Door Bar Installation

Part # 104

NOTE: Place seat in car and determine the height of this bar. When at all possible, place this bar as close to the rocker sill as possible.

- Place tube in car and determine notch angle & rotation on Main Hoop end.
- Notch tube.
- Determine notch placement on forward end of tube.
- Notch tube till it fits in between Main Hoop and Door Frame Bar.
- When satisfied with fit, tack the front in several places and only 1 small tack on the Main Hoop end making sure tube is parallel to rocker sill.



Upper Door Bar Prep

You will need to make some clearance in the front part of the door opening for the Upper Door Bar.

- Measure 2 3/4" from the bottom of the dash mount bracket.
- Using the mark you just made as the center for the pilot drill on the hole saw, make a notch where the Upper Door Bar will pass through the door opening. **(NOTE: Drill a hole in the Door Frame bar with the pilot drill.)**

NOTE: Use a 1 3/4" hole saw with a pilot drill. You will weld the hole from the pilot drill when finished and the door bar will cover the welded hole.



Upper Door Bar Installation

Part # 151

- Determine the notch angle and rotation of the Upper Door Bar where it meets the Main Hoop.
- Make notch on Main Hoop end.
- Notch this end till the rear most bend just clears the body. The bottom of this tube should land about 2" up from the Hoop mounting plate.
- Make any necessary adjustments to the notch.
- Determine the notch angle and rotation on the front of the Door Bar.
- Make notch **(NOTE: Don't notch to final fit at this point.)**
- Make any necessary adjustments to the notch.
- Once you can get the Door Bar somewhat in place, close the door and check for clearance. Make sure the Door Bar does not stick out too far and hit the door skin on the rear bend or the anti-intrusion beam in the door.
- Once your sure the Door Bar will clear the door skin, finish the notch on the front.
- Check to make sure the Door Bar clears the Anti-intrusion bar inside the door.
- Trim door as necessary so door will close easily.
- Once satisfied with fit, tack the FRONT ONLY in several places and .



Door Bar Vertical Installation

Part #'s 105, 106 & 107

- Determine where the **front** and **rear** vertical pieces will go and mark locations. We like to place these as close to the bends as possible.
- Determine the notch angle for the top.
- Notch till pieces fit locations marked in first step.
- Use a square and square the bottom of the vertical to the lower door bar and tack in place when satisfied with fit.
- Now measure the distance between the two vertical pieces you just installed. Split the difference and mark location of the center vertical tube.
- Notch till piece fits location marked.
- Tack in place

At this point you need to remove the Dash Bar and Eyebrow Bar. Now remove the Door Frame Bars with the Door Bars still attached to the Door Frame Bar. Weld the OUTSIDE ONLY of the Door Bars and the Firewall Tubes to the Door Frame Bar. It is not possible to get a 360 degree weld on these tubes without following this step.

Once you have made these welds, reinstall back in car and tack into place.



Roof Diagonal Installation

Part # 113

NOTE: This piece is not symmetrical. The end with more bend goes to the Drivers side. Take your time with the compound notch (Pic 1) on passenger side. Remove small amounts at a time to get correct notch rotation and angles.

- Position the Roof Diagonal and mark placement of the notch for the door frame bar on the passenger side.
- Check rotation and angle. Make any necessary adjustment so the bar sits vertical.
- Once happy with the first notch, mark for the second notch.
- Make second notch. **(NOTE: Again remove small amounts till the angle and rotation are correct.)**
- Check fitment and make any necessary adjustments.
- Position back in car and determine location and angle of notch on drivers side. **(NOTE: This end should land on the Eye-brow bar.)**
- Mark location of notch.
- Notch drivers end and check fitment.
- Make any necessary adjustments to notch angle and rotation. **(NOTE: Do not tack this bar in place at this time.)**



Tube Gussets

Part # 123

NOTE: Refer to the 3D renderings at the front of the manual for placement of these tubes.

Welding Process

- With the Roof Diagonal removed, place a weld where the Roof Diagonal will cover the joint of the Door Frame Bar and the Main Hoop on passenger side. Refer to Pic 1 above.
- Once this weld is complete, tack the Roof Diagonal in place.
- Completely weld tubes to all perches.
- Weld the rest of the components in a systematic way. Don't weld everything on one side of the car and then weld the other side. Weld from side to side, meaning, if you make one weld on one side of the car, make the same weld on the opposite side of the car. This will help prevent the cage from moving around from the welding heat.

Gusset Placement

Once all of the joints have been welded, position gussets at any joint where 2 tubes intersect without a 3rd tube. The exception being the Seat Brace Bar and the Door Bar Verticals.

Gusset Locations (Refer to 3D diagrams at beginning of manual.)

- Rear down tubes at main hoop.
- Firewall tubes at Forward Down Tube.
- Both ends of Door Bars.
- Both ends of Dash Bar.
- Passenger side Forward Down Tube at Eyebrow Bar.
- Driver side Forward Down Tube at Main Hoop.

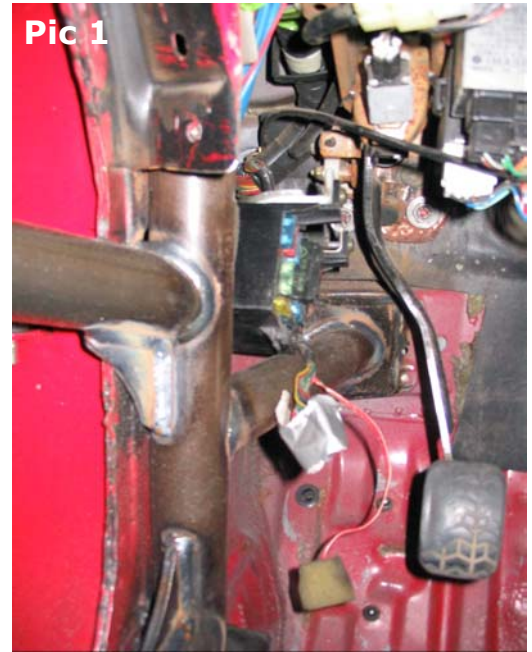

Heater Blower Installation

- Position the heater blower in the car using the stock bottom mount on the firewall.
- Make sure the blower is up tight at the top where the fresh air comes in and locate where the tab supplied in the kit will go on the Forward Down Tube.
- Grind the tab as needed for proper fit.
- Tack in place.
- Remove blower and weld tab in place.
- Once the weld is cool, bolt the blower in place using the stock lower mount on the firewall and the tab you just welded in.

NOTE: The upper tab on the blower will wedge between the dash bar and the firewall as shown in pic 3.



Dash Preparation & Install

- Remove all ducting from the back side of the dash.
- Remove the glove box.
- Discard all of the vent ducting (#1, Pic 3) but keep the defrost ducting.
- Cut the side window defrost ducting at #2, Pic 3 and tape the end closed for maximum airflow to the windshield.
- Notch the dash where the Door Frame Bars will pass through.
- Place dash in car and determine if any notching is required for the Door Bars. If so, mark locations and notch to fit.
- Once fitting is complete, reinstall the defrost ducting.
- Reinstall the dash.

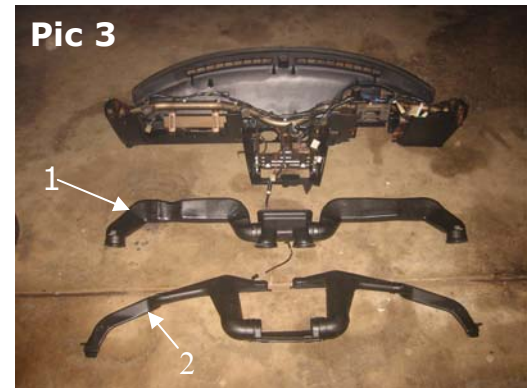

Optional Dash Bar Installation

Part #124

NOTE: This piece is very challenging to install. Take your time and remove small amounts of material at a time so as not to make it too short. As with the Standard Dash Bar, this piece should be left just a little bit long so it will push the Door Frame Bars out tight against the body of the car.



- Measure off each end of the Dash bar and place marks every 1/4". These are reference marks only so you can make sure and remove equal amounts of material from each end of the tube when notching.
- Remove 1 of the Door Frame bars and set the Dash bar in place.
- Determine notch angle and rotation.
- Notch 1 end only and check for proper notch angle and rotation.
- Make any necessary adjustments to angle and rotation.
- Duplicate notch on other end of tube, removing an equal amount of material as you did the first notch.
- Try and reinstall the Door Frame bar you just removed with the Dash bar in place.
- If the Door Frame bar will not go in place, remove equal amounts of material from both ends of the Dash bar using the reference marks till you can get the Door Frame bar in place. **(NOTE: Again, remove small amounts at a time. The marks are for reference only. You do not need to notch to the next mark if the tube is too long. You can notch anywhere in between the marks as long as you remove equal amounts from both ends.)**
- Once you are happy with the fit, place small tacks on each end of the Dash bar and re-tack the Door Frame bar in place.
- Continue on Page 17 with Eyebrow/Windshield bar Installation.